

2-YEAR WARRANTY

STEPLADDERS

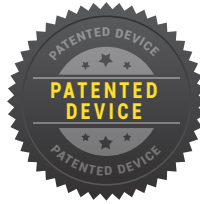

NEW



TWIN STEP



***COMFORTABLE!**
Non-slip steps in punched steel

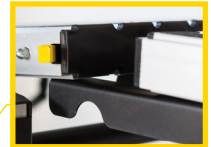
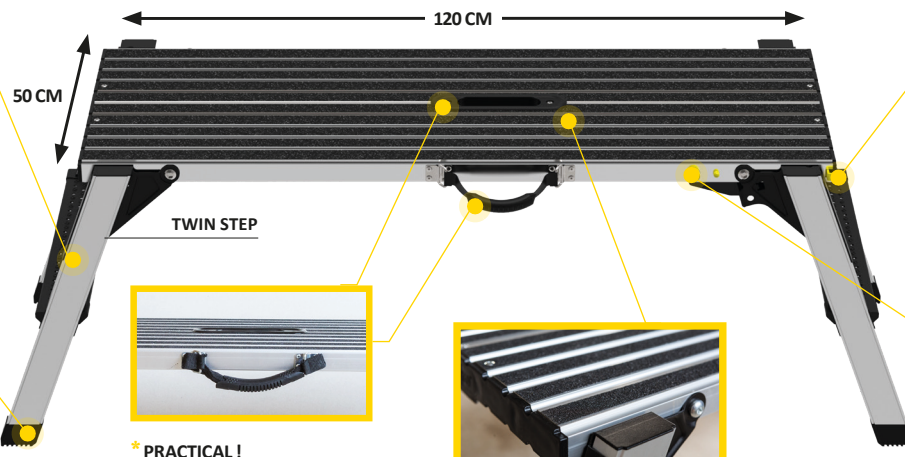

***EASY CLIPPING**
to assemble two platforms



***STABLE!**
Non-slip feet



***PRACTICAL!**
Handle for easy carriage + handle in the middle of the product

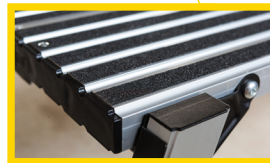

***NON-SLIP!**
Platform covered with non-slips strips 120 x 42 cm



***SAFE!**
Knob for automatic locking

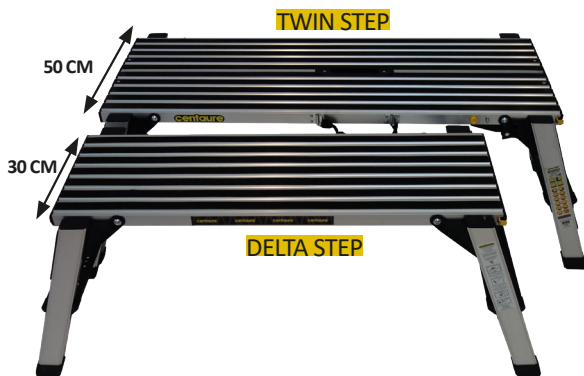

Very large working area



QUICK AND TOOL-LESS ASSEMBLY⁽¹⁾

(1) 2 platforms maxi

***COMPACT!**
Easy to carry and transport



DELIVERED IN A PRINTED CARD BOX AND EASY TO CARRY



Item code	Barcode	Height (m)	Width (m)	Depth (m)	Folded product (L x W x D) (m)	Folded product (L x W x D) (m)	Weight (kg)
452700	3 172965 1 102082	2.50	1.20	0.50	1.20 x 0.17 x 0.50	1.20x0.17x0.52	13.50

MAXIMUM LOADING CAPACITY 150 KG.